

Geoprobe® 6712DT

Strong Direct Push Features in a Modular, Easy-to-Use Machine

The Geoprobe® 6712DT modular drilling rig is perfect for small- to medium-sized direct push projects. It breaks into three components if necessary for easy transport to remote sites.



The track section of the 6712DT is lowered to a site on the mountainside to advance 4.25 in. hollow stem augers to install 2.0 in. monitoring wells.

Modular Machine Design

- Can be assembled and disassembled in three parts
- Pick Weight Under 2,000 lb per Component
- Simple Hydraulic Design

Geoprobe® GH63 Series Percussion Hammer

- Modular percussion power cell technology
- Single Speed Bi-directional Rotation

Rear Blade (Stabilization & Tool Transport)

Wireless & Tethered Remote Drive

Winch Mast

- Optional Mast & Winch System
- 2,500 lbf winch

Drill Mast

- 36,000 push
- 48,000 pull
- Sideshift (optional)

Augerhead

- Two-Speed Augerhead, 2,500 ft/lb (optional)
- Up to 150 rpm

Controls

- Simple control panel design
- Manual controls provide tactile feel





Weight & Dimensions

Base Unit Weight: 5,900 lb. (2,676 kg.)
 With Typical Options: 6,480 lb. (2,939 kg.)

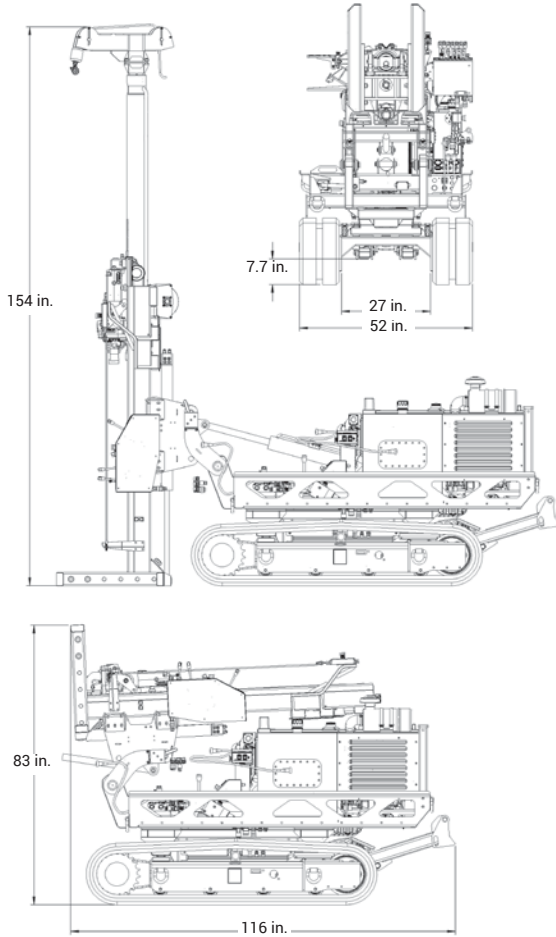

View full specifications online at
geoprobe.com/6712dt

Tooling

Typical Geoprobe® Tooling for the 6712DT

- 60-in. Direct Push Tooling
- Probe Rod Sizes: 3.75 in., 3.5 in., 3.25 in., 2.25 in., 1.5 in., 1.25 in.*
- Macro Core® Soil Sampling (MC5, MC7)
- Dual Tube Soil Sampling (DT37, DT35, DT325, DT22)
- Groundwater Sampling (SP22, SP16)
- Prepacked Monitoring Well Installations (2.0 in., 1.5 in., 1.0 in., 0.75-in.)
- Direct Image® Tooling
- Interlocking Split Spoon Sampler

* Center Rod Use Only

Rig shown with optional features. Weights & dimensions subject to change without notice.

6712DT Options

Machine Modules

212598	Drill Mast
222719	Drill Mast with Sideshift
400016	CPT Drill Mast
224702	Low Clearance Drill Mast with Sideshift
212597	Standard Undercarriage
222720	Lightweight Undercarriage

Augerhead

213942	Two Speed Augerhead Attachment
--------	--------------------------------

Automatic Drop Hammer

213894	Automatic Drop Hammer, 140 lb.
217074	Drop Hammer Mounting Brackets
221820	Automatic Drop Hammer, 170 lb. Expansion Kit
210126	Weight, 65 kg.
217744	Drop Rack Suitcase Weight Assembly

Mast / Winch

214078	Hydraulic Winch and Mast
400098	Hydraulic Winch and Mast (No Sideshift)

Rotational Safety Cage

223073	Safety Cage
400066	Safety Cage (Clears Drop Hammer)

Water / Mud Pumps

217391	Moyno® 2L4 Pump Kit
--------	---------------------

Hydraulic Extruder

222613	5 ft. Hydraulic Extruder Kit
217396	5 ft. Hydraulic Extruder with Moyno® 2L4 Pump
221929	3 in. Shelby Tube Cradle

Rod Racks

212306	Locking Side Mount Rod Rack
209257	Side Mount Rod Rack
211734	Side Rack Mount Blank

Toolboxes

220333	48 in. Toolbox
--------	----------------

Other

228236	Wireless Radio Track Drive Option
214244	Field Service Kit
217741	Drop Rack Weight Assembly with Attachment Point

Drop Rack

207443	Drop Rack System with Utility Rack
207659	Drop Rack System with Rod Rack
213990	Drop Rack with 50 gal. Pressure Washer
207104	Drop Rack System with 150 gal. Tank
209445	Water Transport System 25 gal.
213932	Yoke Vise and Mounting Bracket
213202	Rear Blade Forks (Pair)
211664	Rear Blade Hanger Blank



The track section of the 6712DT is lowered to a site on the mountainside to advance 4.25 in. hollow stem augers to install 2.0 in. monitoring wells.



Hydraulic Winch and Mast (214078)



2 Speed Augerhead Attachment (213942)



Automatic Drop Hammer (213894)



Extruder w/ 2L4 Mounting Kit (217396)



Locking Side Mount Rod Rack (212306)

Rig shown with optional features. Weights & dimensions subject to change without notice.